

DETERMINATION OF FRICTION COEFFICIENT BETWEEN ALUMINUM SEMI-FINISHED AND PLASTIC DEFORMATION TOOLS

**ALIN-MARIAN CAZAC¹, DORU COSTIN DARABONT²,
CONSTANTIN BACIU³, MIHAI-ADRIAN BERNEVIG-SAVA⁴,
COSTICA BEJINARIU⁵**

Abstract: Knowing the friction coefficient to plastic deformation is needed because on the basis of it is estimated the necessary deformation forces depending on which is chosen the deformation machine, is determined manner in which deformation occurs and according to this is established the deformation technology. The paper presents theoretical and experimental conditions for determining the friction coefficient between semi-finished deformation tools, in the case of plastic deformation of the aluminium by rings pressing method. Also, are explained, processed and discussed the results of experimental tests.

Key-words: aluminum, friction coefficient, rings method

1. INTRODUCTION

When processing by plastic deformation friction coefficient μ is the characteristic size, which determines the friction conditions between the workpiece and tool.

In most of deformation processes, the value of this coefficient is not known, and needs to be estimated. This estimate, is made with a degree of uncertainty rather large, producing errors in calculating forces and mechanical work deformation. These errors become extremely large at volumetric deformation because the friction

¹ „Gheorghe Asachi” Technical University of Iasi

² INCDPM „Alexandru Darabont”, 35 A, Ghencea Blv, Sector 6 ,061692, Bucharest

³ „Gheorghe Asachi” Technical University of Iasi

⁴ „Gheorghe Asachi” Technical University of Iasi

⁵ „Gheorghe Asachi” Technical University of Iasi, costica.bejinariu@yahoo.com,
Tel.: +4-074-575-0286

mechanical work is in this case a substantial part of the total mechanical work of deformation.

Determining the value of the friction coefficient μ can be done through experiment and calculation, one of the most advantageous methods is the rings pressing [Bejinariu, 2008; Burgdorf 1967].

2. THEORETICAL CONSIDERATIONS

The method consists in testing the cylindrical annular rings under pressure. Rings made of provided material for workpiece, prepared and properly lubricated are subjected to axially press between two planar and parallel surfaces.

Modification of the geometric dimensions can make inferences about the conditions of friction that have existed during rings pressing. Rings pressing sketch is presented in figure 1, where:

- h , r_i , r_e - height, inner radius respectively outer radius of the specimen before deformation;

- h_1 , r_{i1} , r_{e1} - height, inner radius respectively outer radius of the specimen after deformation;

- r_s - ridge flow radius.

The specimen is divided into two areas:

- (1) - $r \in [r_s, r_e]$ - material flows radially outward;

- (2) - $r \in [r_i, r_s]$ - material flows radially inwards.

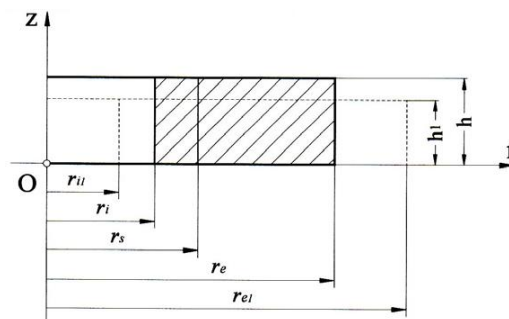

Fig. 1. Rings pressing sketch.

Those two areas are separated by a ridge flow corresponds to the radius r_s .

Are made following simplifying assumptions

- neglect of elastic deflection;
- their own mass and inertial forces are negligible compared to the forces that produce deformation;
- deformation tools behave like rigid bodies;
- neglecting barrel effect is neglected;
- deformation resistance is considered homogenous throughout the mass of the test specimen;

• on the faces of the specimen is considered a Coulomb type friction with a constant friction coefficient μ .

As a basis for theoretical considerations, it is established that determines the velocity field to cinematic rings pressing. Velocity field satisfies the continuity condition and is concurring with the assumptions stated above. Friction on the front faces of the specimens is determining the position of ridge flow r_s .

Corroborating these elements, result liaison relationship between the dimensions of the specimen and the friction coefficient.

$$e^{\frac{2\mu}{h}(r_e-r_s)} + \frac{2}{\sqrt{3}} \int_{r_e}^{r_s} \frac{r_s^2}{r\sqrt{3r^4+r_s^4}} e^{\frac{2\mu}{h}(r-r_s)} dr - e^{\frac{2\mu}{h}(r_s-r_i)} - \frac{2}{\sqrt{3}} \int_{r_i}^{r_s} \frac{r_s^2}{r\sqrt{3r^4+r_s^4}} e^{\frac{2\mu}{h}(r_s-r)} dr = 0 \quad (1)$$

From the dimensions of the specimen, the friction coefficient μ in the relation (1) is the only quantity that influences the position of the ridge flow.

Conversely if specimen dimensions are known, is sufficient to know the value of r_s ridge flow position in order to unambiguously determine friction coefficient μ .

At rings pressing method the specimen is axial pressed between two planar and parallel surfaces to a certain amount $\Delta h = h - h_1$. Δh value has to be selected so small that the variation of the radius of ridge flow r_s during deformation can be neglected.

Taking into account the constancy law volumes, ridge flow radius may be calculated based on both the inside and outer diameter variation.

On the basis of the variation of the outer diameter, result:

$$r_s = \sqrt{\frac{r_e^2 h - r_{e1}^2 h_1}{h - h_1}} \quad (2)$$

Having the radius of the ridge flow r_s , calculated by the equation (2), friction coefficient μ is calculated by numerical solving of the equation (1).

3. EXPERIMENTAL CONDITIONS

3.1. Material

Aluminum EN AW-1050A [Al 99,5], conform SR EN 485-X – Aluminum and aluminum alloys. Sheets, strips and thick plates.

As delivered, the laminated sheet form with a thickness of 10 mm and the following chemical composition: %Al = 99,495; %Si = 0,143; %Fe = 0,213; %Cu = 0,021; %Mn = 0,004; %Mg = 0,050; %Cr = 0,003; %Zn = 0,021; %Ni = 0,008; %Ti = 0,006; %Pb = 0,005; %Sn = 0,011; %Ca = 0,003; %Co = 0,002; %V = 0,011; %Na = 0,004.

3.2. Specimen

The shape and dimensions of the specimen used are shown in figure 2. For experiments, preparing test specimens included the following: obtaining specimens by

fine adjustments and lubrication with zinc stearate.

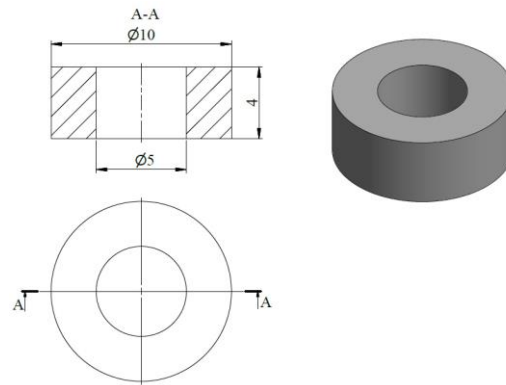

Fig. 2. Shape and dimensions of the specimen.

Specimen Al_00 was made of aluminum sheet Al 99.5 and represents the initial specimen in non-deformed state. Al_01 specimens, Al_02 ..., Al_12 are made of the same material, but severely plastic deformed by Ghosh process [Ghosh, 1988], the values of 01, 02 ... 12 representing the passes to severe plastic deformation

In figure 3 (a) represents the rings before pressing, and Fig. 3 (b) rings after pressing.



Fig. 3. a) rings before pressing; b) rings after pressing

The specimens are axial pressed between two planar and parallel surfaces to a certain amount $\Delta h = 0,5 \text{ mm}$ this value has to be selected so small that the variation of the radius of ridge flow r_s during deformation can be neglected. For deformation it was used a laboratory hydraulic press.

4. EXPERIMENTAL RESULTS

As a result, the experimental tests carried out under the conditions shown were obtained friction coefficient values, shown in table 1.

Table 1. Friction coefficient values.

Specimen	Dimensions [mm]						Calculated parameters	
	initial			final			r_s [mm]	μ [-]
	h	r_i	r_e	h_l	r_{i1}	r_{e1}		
Al_00	4,00	2,50	5,00	3,50	2,37	5,20	3,27	0,191
Al_01	4,00	2,50	5,00	3,50	2,39	5,21	3,16	0,188
Al_02	4,00	2,50	5,00	3,50	2,42	5,22	3,04	0,186
Al_03	4,00	2,50	5,00	3,50	2,44	5,23	2,92	0,180
Al_04	4,00	2,50	5,00	3,50	2,45	5,24	2,79	0,169
Al_05	4,00	2,50	5,00	3,50	2,46	5,24	2,79	0,152
Al_06	4,00	2,50	5,00	3,50	2,48	5,25	2,66	0,148
Al_07	4,00	2,50	5,00	3,50	2,50	5,26	2,52	0,146
Al_08	4,00	2,50	5,00	3,50	2,50	5,26	2,52	0,146
Al_09	4,00	2,50	5,00	3,50	2,52	5,27	2,36	0,144
Al_10	4,00	2,50	5,00	3,50	2,52	5,27	2,36	0,144
Al_11	4,00	2,50	5,00	3,50	2,54	5,28	2,20	0,140
Al_12	4,00	2,50	5,00	3,50	2,56	5,29	2,03	0,141

Based on the initial dimensions h , r_i , r_e of the specimen, the final measured dimensions h_l , r_{i1} , r_{e1} , was determined ridge flow radius r_s by the relation (2). This value, together with dimensional values enter into transcendental equation (1), and by its numerical solving we have obtained the friction coefficient the corresponds to passes 01, 02, ..., 12 at severe plastic deformation. The evolution of the friction coefficient with the number of passes and hence the degree of cumulative strain is shown in figure 4.

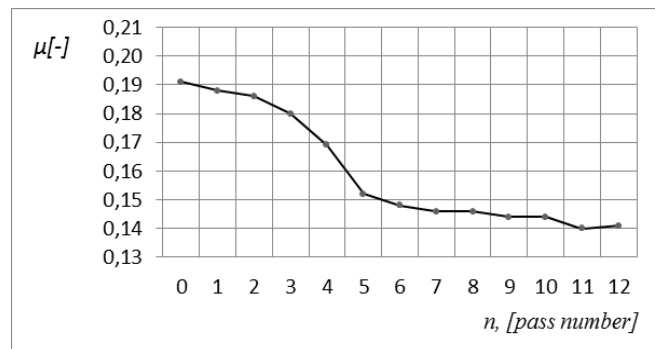

Fig. 4. The variation the friction coefficient with the number of passes

5. CONCLUSIONS

Knowing the friction coefficient to plastic deformation is needed because on the basis of it is estimated the necessary deformation forces depending on which is chosen the deformation machine, is determined manner in which deformation occurs and according to this is established the deformation technology

Rings pressing method to determine the friction coefficient at plastic deformation presents a clear advantage compared to other methods used, namely that does not require knowing the pressing forces. By this method, friction coefficient is determined on the basis of change in dimensions of the rings after plastic deformation.

Severe plastic deformation of aluminum Al 99.5, with increasing the cumulative degree of deformation on passes the friction coefficient between the material and deformation tools significantly decreases between passes 3 and 6.

REFERENCES

- [1]. Bejinariu C., *Indirect Cold Extrusion of Steels*, Tehnopress Publishing, Iasi 2008, ISBN 978-973-702-582-1.
- [2]. Burgdorf, M. – *Determinarea prin metoda refulării inelelor a coeficientului de frecare pentru procedeul deformării volumice*, Düsseldorf, Industrie - Anzeiger, nr. 39, mai 1967.
- [3]. Ghosh, Amit K., – Method of producing a fine grain aluminium alloy using three axes deformation, US patent US4721537, 1988-01-26.